

BUILDING PLANS

RESIDENTIAL
BUILDING INSPECTIONS DEPARTMENT
www.ci.blaine.mn.us



This handout is intended only as a guide to the subject matter covered herein and is based in part on the 2007 Minnesota State Building Code. While every attempt has been made to insure the correctness of this handout, no guarantees are made to its accuracy or completeness. Responsibility for compliance with applicable codes and ordinances falls on the owner or contractor. For specific questions regarding code requirements, refer to the Minnesota Building Code or contact your local Building Department.

The most important step in the permit process is the submittal and review of building plans. The purpose of the plans is to provide a detailed written document of the scope of your project. If you are having a number of contractors bid on your project, it is in your best interests if you provide plans independent of a contractor. That way all of the contractors that bid on your project will be bidding on the same conditions and you will more easily be able to compare bids.

When the City receives your plans, a staff member will review your plans to determine in advance that the proposed work complies with the various building rules. The goal is to uncover potential problem areas while the project is still on paper and save you costly corrections later. Applicants are asked to provide two sets of plans. The City retains one set, the other set will be returned to the permit applicant with any corrections noted.

Plans must be detailed. They must also be neatly drawn and drawn to a useable scale. One-quarter inch to one foot is a common scale for floor plans and building plans. Typical residential plans would include a site plan (decks, additions, and garages only), foundation plans, floor plans, cross sections, elevations, details of various structural components, and a window schedule. Plans should be dimensioned and include information on use of rooms, wall and ceiling finishes, and lumber sizes and spacing. It is helpful if each page identifies the address of the project as well as the owner's name.

You can prepare your own plans or your contractor or a drafting service can prepare them for you. 8 ½ X 11 sheets can be used for projects that aren't too large.

If your project is very complex, you may find it advantageous to hire a professional designer to assist you. Also, if your design involves complicated framing techniques or the use of steel I-beams, for example, you may be required to verify that the designs meet code as a part of the plan review process. The Building Department may require that a licensed engineer provide this verification.

Once your plans are reviewed and approved, it is very important that you do not change the plans without prior approval of the Building Department. If you change the plans, you run the risk of code violations and negate the purpose of having the plans reviewed in the first place.

The following is a description of what should be included on various portions of the plans:

Site Plan

The site plan is a scale drawing of the lot showing the location of each building on the lot. The site plan should indicate the address of the property, the scale to which the drawing was prepared, and indicate the orientation of the drawing with a north arrow. The size of each building must be shown as well as the distance from each building to the property lines and to other buildings. The new construction should be clearly identified on the site plan. Any water features, retaining walls, or other physical features should be shown. Distances from buildings must be shown to property lines and not streets, sidewalks or alleys. If you do not know the location of your property lines, you may need to have your lot surveyed. Many surveys are on file with the City. Check with us to see if we have a survey for your lot.

Foundation Plans

Foundation plans indicate the path and location of the footings and general notes on the foundation design. They should be fully dimensioned.

Elevations

An elevation plan is a view of the building, as one would see it from each side of the building. Elevations help to show the scale of the project, the building height, and exterior finishes. They also help to determine the number of stories of a building, which can effect certain building code requirements.

Floor Plans

Floor plans should be submitted for each floor affected by a building project. The floor plan should show the location and identity of each room, room dimensions, locations of windows and doors, fixture locations, and items such as smoke detectors. A window schedule should be provided with the floor plans. The schedule should indicate the location of the window, the manufacturer, the window size (manufacturer's model number), and if the window is safety glazed.

Cross Sections

Cross sections show a view through the building's framework from foundation to the peak of the roof. Multiple cross sections may be necessary to portray the various work proposed. Cross sections should show the footing width and depth including rebar placement; foundation type (masonry, concrete, or wood), foundation height and thickness, rebar locations, framing details; anchor bolt locations; sill plates, floor joist size and spacing, stud size and spacing, exterior and interior sheathing, exterior wall coverings, and insulation and vapor barriers; and roof framing including truss drawings or joist and rafter size and spacing, roof pitch, eave details, insulation and vapor barriers, roof sheathing, underlayment, ventilation methods, ice and water barrier installations, and roofing type. Descriptive notes may be included to address specific issues such as treated plates, header sizes, fastener schedules, etc.

TYPICAL FOUNDATION PLAN FOR DWELLING ADDITION

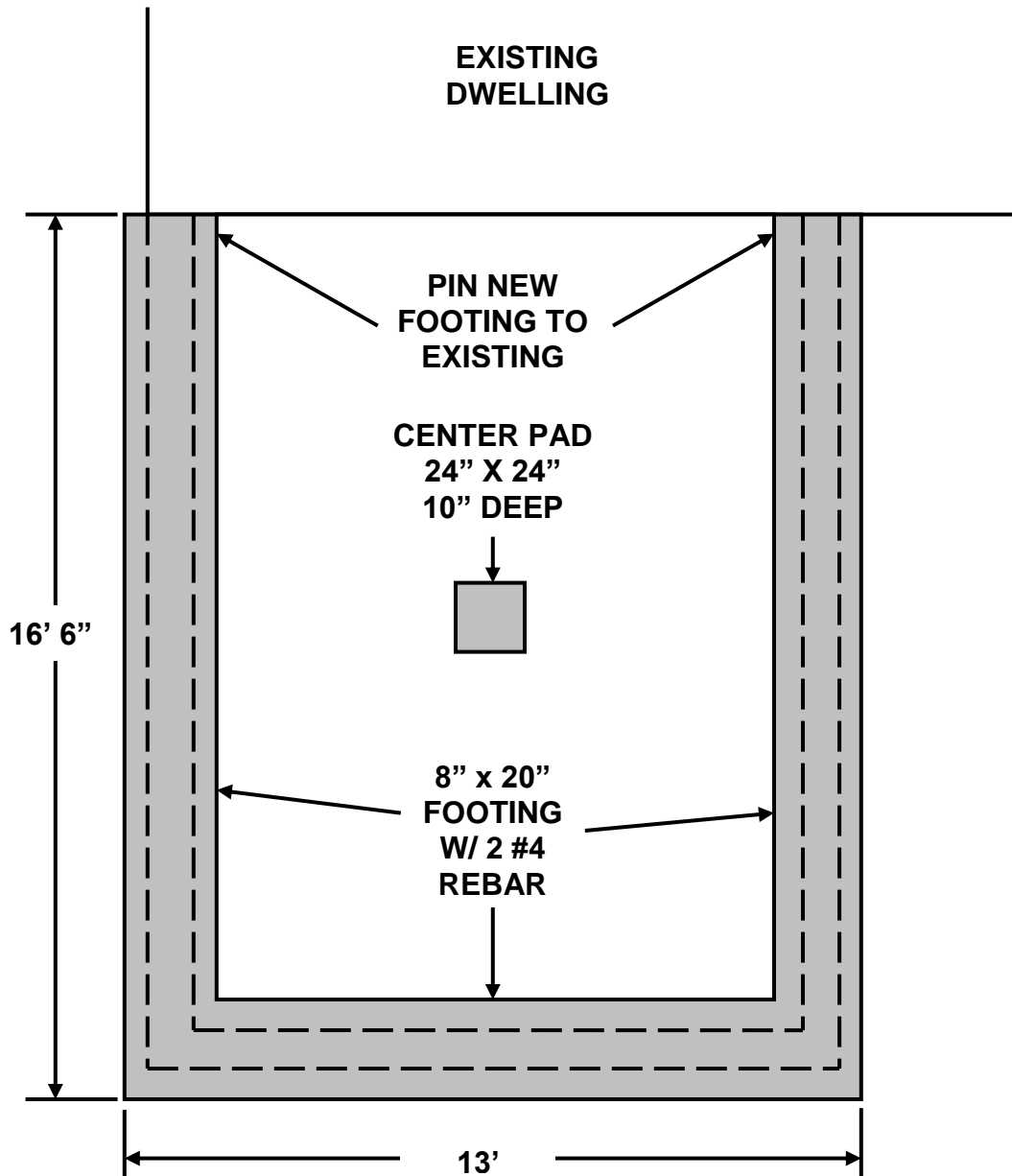

Scale 1/4" = 1 Ft

TYPICAL BUILDING ELEVATIONS

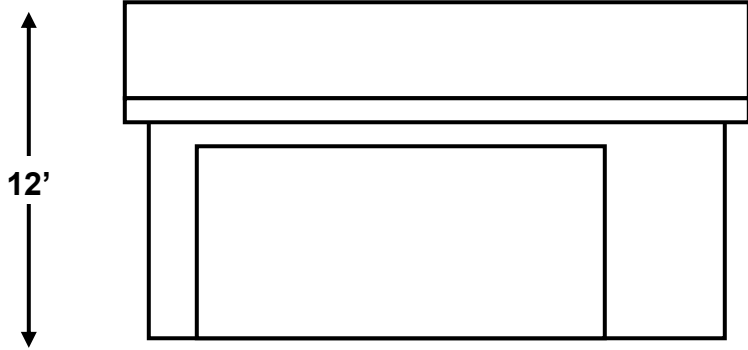

FRONT

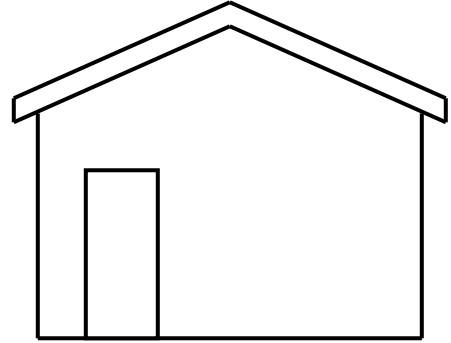

**RIGHT
SIDE**

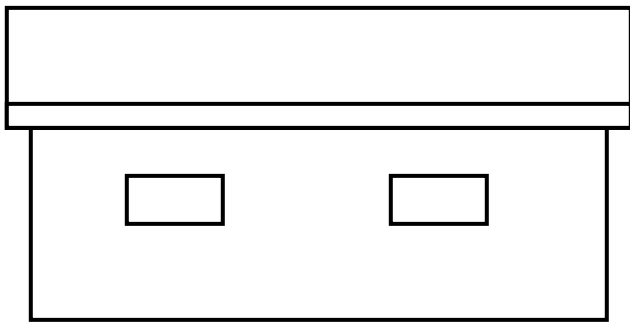

REAR

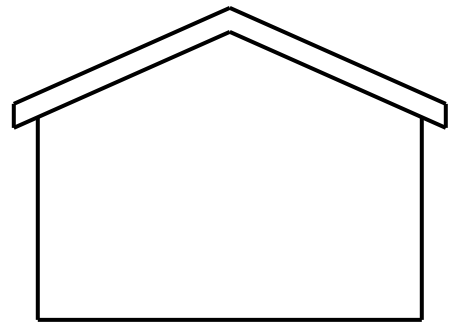

**LEFT
SIDE**

SCALE ¼ INCH = 1 FOOT

TYPICAL GARAGE CROSS SECTION

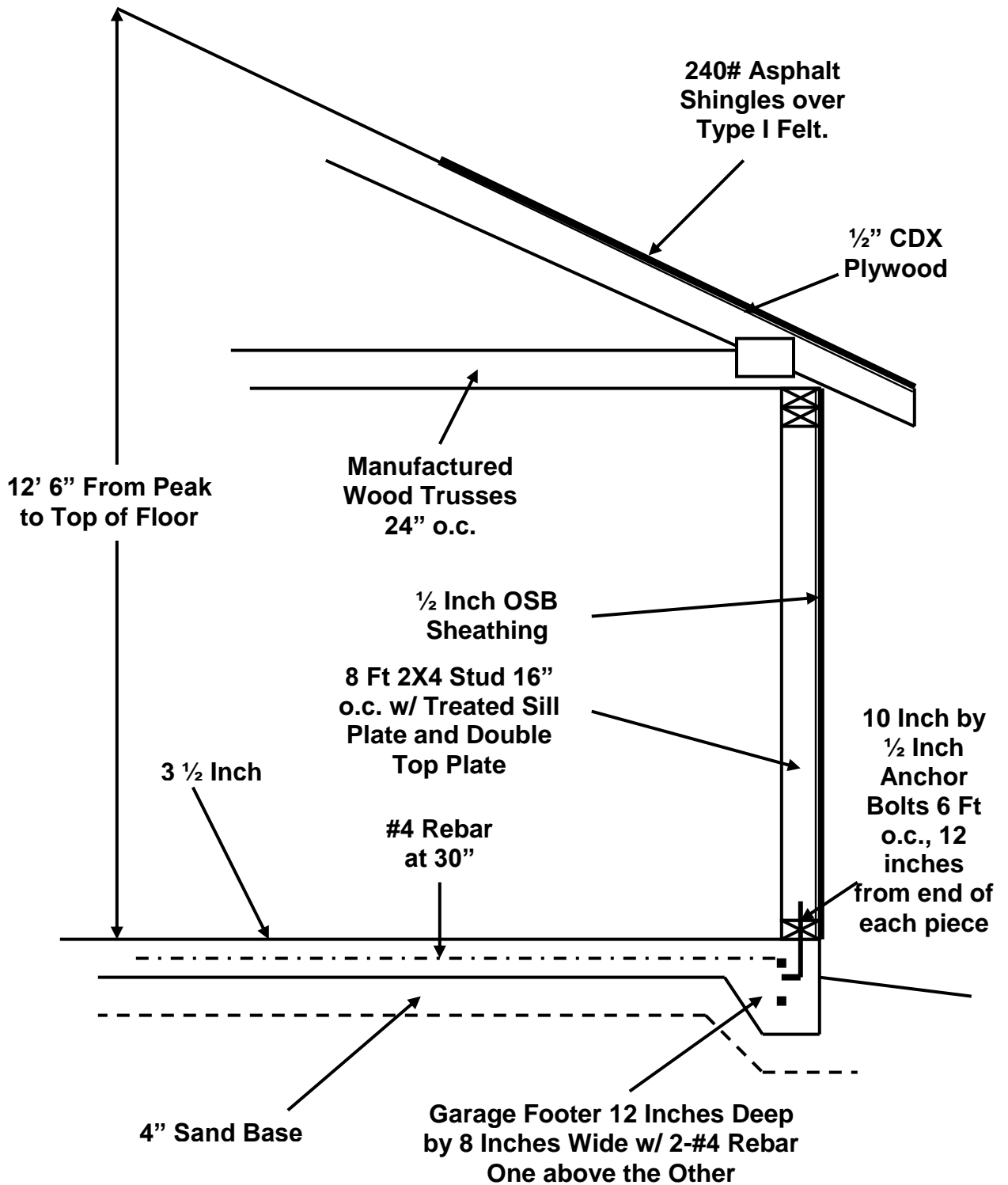

SCALE 1/4" = 1 FOOT

